

Agilent Technologies
Innovating the HP Way

DECLARATION OF CONFORMITY

According to ISO/IEC Guide 22 and CEN/CENELEC EN 45014

Manufacturer's Name: Agilent Technologies Japan, Ltd.
Manufacturer's Address: Component Test PGU-Kobe
1-3-2, Murotani, Nishi-ku, Kobe-shi,
Hyogo, 651-2241 Japan

Declares, that the product

Product Name: Down converter Unit, 10 MHz to 12.6 GHz
Model Number: 43521A
Product Options: All options and customized products based on the above

Is in conformity with:

EMC European Council Directive 89/336/EEC and carries the CE-marking accordingly
EMC Standards required by the Australia Radio Communications Act
CISPR 11:1990 / EN 55011:1991 / AS/NZS 2064.1- Group 1 Class A ^[1]
EN61000-3-2:1995 / IEC61000-3-2:1995
EN61000-3-3:1995 / IEC61000-3-3:1994
EN50082-1:1992
IEC 801-2:1991 (4 kV CD, 8 kV AD)
IEC 801-3:1984 (3 V/m 80% AM 27 - 1000 MHz)
IEC 801-4:1988 (1 kV power line, 0.5 kV Signal line)

Safety European Council Directive 73/23/EEC and carries the CE-marking accordingly
IEC 61010-1:1990+A1+A2 / EN 61010-1:1993+A2
CAN / CSA C22.2 No. 1010.1-92

Additional Information:

LEDs in this product are Class 1 in accordance with EN 60825-1:1994.

^[1] The product was tested in a typical configuration.

Dec. 7, 1999

Date

Name Yukihiko Ota / Quality Engineering Manager

For further information, please contact your local Agilent Technologies sales office, agent or distributor.

Safety Summary

When you notice any of the unusual conditions listed below, immediately terminate operation and disconnect the power cable.

Contact your local Agilent Technologies sales representative or authorized service company for repair of the instrument. If you continue to operate without repairing the instrument, there is a potential fire or shock hazard for the operator.

- Instrument operates abnormally.
- Instrument emits abnormal noise, smell, smoke or a spark-like light during the operation.
- Instrument generates high temperature or electrical shock during operation.
- Power cable, plug, or receptacle on instrument is damaged.
- Foreign substance or liquid has fallen into the instrument.

Herstellerbescheinigung

GERÄUSCHEMISSION

LpA < 70 dB
am Arbeitsplatz
normaler Betrieb
nach DIN 45635 T. 19

Manufacturer's Declaration

ACOUSTIC NOISE EMISSION

LpA < 70 dB
operator position
normal operation
per ISO 7779

Caution



Do not exceed the operating input power, voltage, and current level and signal type appropriate for the instrument being used, refer to your instrument's Function Reference.



Electrostatic discharge(ESD) can damage the highly sensitive microcircuits in your instrument. ESD damage is most likely to occur as the test fixtures or cables are being connected or disconnected. Protect them from ESD damage by wearing a grounding strap that provides a high resistance path to ground. Alternatively, ground yourself to discharge any static charge built-up by touching the outer shell of any grounded instrument chassis before touching the test port connectors. The measurement input terminal "RF-IN" is vulnerable to ESD. Attaching the power limiter to the terminal can effectively minimize ESD damage which may occur in your instrument.

Agilent 43521A Downconverter Unit

Operation Manual

SERIAL NUMBERS

This manual applies directly to instruments with serial number prefix JP1KG.
For additional important information about serial numbers,
read “Serial Number” in Appendix A of this Manual.

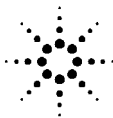

Agilent Technologies
Innovating the HP Way

Agilent Part No. 43521-90000
Printed in JAPAN December 1999

Second Edition

Notice

The information contained in this document is subject to change without notice.

This document contains proprietary information that is protected by copyright. All rights are reserved. No part of this document may be photocopied, reproduced, or translated to another language without the prior written consent of the Agilent Technologies Japan, Ltd.

Agilent Technologies Japan, Ltd.
Component Test PGU-Kobe
1-3-2, Murotani, Nishi-ku, Kobe-shi,
Hyogo, 651-2241 Japan

Manual Printing History

The manual's printing date and part number indicate its current edition. The printing date changes when a new edition is printed. (Minor corrections and updates that are incorporated at reprint do not cause the date to change.) The manual part number changes when extensive technical changes are incorporated.

July 1999 First Edition (part number: 43521-90000)
December 1999 Second Edition (part number: 43521-90000)

Safety Summary

The following general safety precautions must be observed during all phases of operation, service, and repair of this instrument. Failure to comply with these precautions or with specific **WARNINGS** elsewhere in this manual may impair the protection provided by the equipment. In addition it violates safety standards of design, manufacture, and intended use of the instrument.

The Agilent Technologies assumes no liability for the customer's failure to comply with these requirements.

Note 43521A complies with INSTALLATION CATEGORY II and POLLUTION DEGREE 2 in IEC61010-1. 43521A is an INDOOR USE product.



Note LEDs in 43521A are Class 1 in accordance with IEC60825-1.
CLASS 1 LED PRODUCT



Ground The Instrument

To avoid electric shock hazard, the instrument chassis and cabinet must be connected to a safety earth ground by the supplied power cable with earth blade.

DO NOT Operate In An Explosive Atmosphere

Do not operate the instrument in the presence of flammable gasses or fumes. Operation of any electrical instrument in such an environment constitutes a definite safety hazard.

Keep Away From Live Circuits

Operating personnel must not remove instrument covers. Component replacement and internal adjustments must be made by qualified maintenance personnel. Do not replace components with the power cable connected. Under certain conditions, dangerous voltages may exist even with the power cable removed. To avoid injuries, always disconnect power and discharge circuits before touching them.

DO NOT Service Or Adjust Alone

Do not attempt internal service or adjustment unless another person, capable of rendering first aid and resuscitation, is present.

DO NOT Substitute Parts Or Modify Instrument

Because of the danger of introducing additional hazards, do not install substitute parts or perform unauthorized modifications to the instrument. Return the instrument to a Agilent Technologies Sales and Service Office for service and repair to ensure that safety features are maintained.

Dangerous Procedure Warnings

Warnings , such as the example below, precede potentially dangerous procedures throughout this manual. Instructions contained in the warnings must be followed.

Warning



Dangerous voltages, capable of causing death, are present in this instrument. Use extreme caution when handling, testing, and adjusting this instrument.

Typeface Conventions

Bold	Boldface type is used when a term is defined. For example: icons are symbols.
<i>Italics</i>	Italic type is used for emphasis and for titles of manuals and other publications. Italic type is also used for keyboard entries when a name or a variable must be typed in place of the words in italics. For example: copy <i>filename</i> means to type the word <code>copy</code> , to type a space, and then to type the name of a file such as <code>file1</code> .
Computer	Computer font is used for on-screen prompts and messages.
HARDKEYS	Labeled keys on the instrument front panel are enclosed in <code>□</code> .
SOFTKEYS	Softkeys located to the right of the LCD are enclosed in <code>⏏</code> .

Certification

Agilent Technologies certifies that this product met its published specifications at the time of shipment from the factory. Agilent Technologies further certifies that its calibration measurements are traceable to the United States National Institute of Standards and Technology, to the extent allowed by the Institution's calibration facility, or to the calibration facilities of other International Standards Organization members.

Warranty

This Agilent Technologies instrument product is warranted against defects in material and workmanship for a period of one year from the date of shipment, except that in the case of certain components listed in *General Information* of this manual, the warranty shall be for the specified period. During the warranty period, Agilent Technologies will, at its option, either repair or replace products that prove to be defective.

For warranty service or repair, this product must be returned to a service facility designated by Agilent Technologies . Buyer shall prepay shipping charges to Agilent Technologies and Agilent Technologies shall pay shipping charges to return the product to Buyer. However, Buyer shall pay all shipping charges, duties, and taxes for products returned to Agilent Technologies from another country.

Agilent Technologies warrants that its software and firmware designated by Agilent Technologies for use with an instrument will execute its programming instruction when properly installed on that instrument. Agilent Technologies does not warrant that the operation of the instrument, or software, or firmware will be uninterrupted or error free.

Limitation Of Warranty

The foregoing warranty shall not apply to defects resulting from improper or inadequate maintenance by Buyer, Buyer-supplied software or interfacing, unauthorized modification or misuse, operation outside the environmental specifications for the product, or improper site preparation or maintenance.

No other warranty is expressed or implied. Agilent Technologies specifically disclaims the implied warranties of merchantability and fitness for a particular purpose.

Exclusive Remedies

The remedies provided herein are buyer's sole and exclusive remedies. Agilent Technologies shall not be liable for any direct, indirect, special, incidental, or consequential damages, whether based on contract, tort, or any other legal theory.

Assistance

Product maintenance agreements and other customer assistance agreements are available for Agilent Technologies products.

For any assistance, contact your nearest Agilent Technologies Sales and Service Office. Addresses are provided at the back of this manual.

Safety Symbols

General definitions of safety symbols used on equipment or in manuals are listed below.



Instruction manual symbol: the product is marked with this symbol when it is necessary for the user to refer to the instruction manual.



Alternating current.



Direct current.



On (Supply).



Off (Supply).



In position of push-button switch.



Out position of push-button switch.



Frame (or chassis) terminal. A connection to the frame (chassis) of the equipment which normally include all exposed metal structures.

Warning



This **Warning** sign denotes a hazard. It calls attention to a procedure, practice, condition or the like, which, if not correctly performed or adhered to, could result in injury or death to personnel.

Caution



This **Caution** sign denotes a hazard. It calls attention to a procedure, practice, condition or the like, which, if not correctly performed or adhered to, could result in damage to or destruction of part or all of the product.

Note



This **Note** sign denotes important information. It calls attention to a procedure, practice, condition or the like, which is essential to highlight.



Affixed to product containing static sensitive devices use anti-static handling procedures to prevent electrostatic discharge damage to component.

Contents

1. Unpacking and Checking the Contents of the Shipment	
Incoming Inspection	1-1
Contents of the Shipment	1-1
2. Connecting 43521A	
Notes on Installation	2-1
Requirements for Operating Environment	2-1
Ventilation Requirements	2-1
Instruction for Cleaning	2-1
Connection to the 4352B and External Signal Source	2-2
Connections on the Front Panel	2-3
Connections on the Rear Panel	2-4
Power Requirements	2-5
Ratings of the Power Source	2-5
Power Cable	2-5
3. Front Panel and Rear Panel	
Front Panel	3-1
1. RF Input Connector	3-2
2. RF Output Connector	3-2
3. LO Output Connector	3-2
4. LO Input Connector	3-2
5. Line Switch	3-2
Rear Panel	3-3
1. 40 MHz Input Terminal	3-3
2. I/O Port	3-3
3. Inlet	3-3
4. 600 MHz Adjustment Knob	3-3
 Replacing the Fuse	3-4
Replacing the Fuse	3-4
4. Rack/Handle Installation	
Rack/Handle Installation	4-1
Option 1CN Handle Kit	4-2
Installing the Handle	4-2
Option 1CM Rack Mount Kit	4-2
Mounting into the Rack	4-2
Option 1CP Rack Mount & Handle Kit	4-2
Mounting into the Rack (with Handles)	4-2

5. Specifications	
Specifications of the 43521A	5-1
RF Power Measurement	5-1
Operating Environment	5-2
Non-Operating Environment	5-2
Others	5-2
System Specifications	5-3
1. When Frequency Band is 10 MHz to 3 GHz	5-3
RF Power Measurement (common to the tester mode and the analyzer mode)	5-3
2. When Frequency Band is other than 10 MHz to 3 GHz	5-3
2-1. Tester Mode	5-3
RF Power Measurement	5-3
Frequency Measurement	5-3
FM Deviation Measurement	5-3
C/N Ratio Measurement	5-3
2-2. Analyzer Mode	5-4
RF Power Characteristics vs. DC Control Voltage Measurement	5-4
Frequency/Tuning Sensitivity Characteristics vs. DC Control Voltage Measurement	5-4
Phase Noise Characteristics vs. Offset Frequency Measurement	5-4
Frequency Transient Measurement	5-4
Spectrum Measurement	5-4
A. Manual Changes	
Introduction	A-1
Manual Changes	A-1
Serial Number	A-2

Figures

2-1. Connections on the Front Panel	2-3
2-2. Connections on the Rear Panel	2-4
2-3. Optional Power Cables	2-6
3-1. Front Panel	3-1
3-2. rear panel	3-3
4-1. Rack Mount Kit Installation	4-1
A-1. Serial Number Plate	A-2

Tables

1-1. List of the Contents of the Shipment	1-1
2-1. Parts Used on the Front Panel	2-3
2-2. Parts Used on the Rear Panel	2-4
3-1. Rating of Fuse	3-4
4-1. Rack Mount Kits	4-1
5-1. RF Power Measurement Accuracy	5-1
5-2. Noise Floor of Phase Noise	5-4
A-1. Manual Changes by Serial Number	A-1

Unpacking and Checking the Contents of the Shipment

This chapter describes how to check the shipping container of your 43521A (Downconverter Unit), the appearance of the product, and the contents of the shipment.

Incoming Inspection

When you receive the product, inspect the shipping container for damage. If the shipping container or cushioning material is damaged, it should be kept until the contents of the shipment have been checked for completeness and the 43521A has been checked mechanically and electrically. The contents of the shipment should be as listed in Table 1-1. If the contents are incomplete, if there is mechanical damage or defect, notify the nearest Agilent Technologies sales office. If the shipping container is damaged, or the cushioning material shows signs of unusual stress, notify the carrier as well as the Agilent Technologies office. Keep the shipping materials for the carrier's inspection.

Warning **To avoid hazardous electrical shock, do not turn on the 43521A when there are signs of shipping damage to any portion of the outer enclosure (for example, covers, panel, or display).**



Contents of the Shipment

The 43521A (Downconverter Unit) includes the following items. Check to see that the contents are complete. If not, contact your nearest Agilent Technologies Sales and Service Office.

Table 1-1. List of the Contents of the Shipment

Name	Agilent Part Number
Downconverter Unit	43521A
43521A Operation Manual	43521-90000
BNC cable (30 cm x 1)	8120-1838
N-N cable (18 cm x 2)	8120-4387
N-N cable (50 cm x 1)	43521-61638
15-pin D-Sub cable	04380-61601
Power cable	8120-4753

Connecting 43521A

The 43521A (Downconverter Unit) is used as part of the 4352S (VCO/PLL Signal Test System). Using the 43521A expands the maximum frequency of the 4352S to 12.6 GHz. This chapter describes how to make connection for the 4352S when associated with the 43521A.

How to use the entire 4352S including the 43521A is described in Chapter 5 of the 4352B Function Reference, while a quick guide to diagnosis is provided in Appendix F of that document. For related sample programs, see “Frequency Transient Measurement” in Chapter 12 of the 4352B GPIB Programming Manual. After the completion of the connection for the 4352S, proceed to the reference.

Note that the 4352B with the firmware of Rev 2.00 or greater is required in order to operate the 43521A.

Notes on Installation

Requirements for Operating Environment

The requirements for the operating environment of the 43521A is the same as those of the 4352B. Use it under the environment shown below.

Temperature: 0°C to 40°C

Humidity: Relative humidity of 95% or less (at 40°C)

Note

The 43521A must be protected from temperature extremes which could cause condensation within the instrument.



Ventilation Requirements

When installing the 43521A, make sure that there is adequate clearance of at least 180 mm behind and 60 mm sides, to ensure adequate ventilation.

Instruction for Cleaning

To prevent electrical shock, disconnect the 43521A's power cable from the power outlet before cleaning. To clean the exterior of the 43521A, wipe the surfaces with a dry cloth or a soft cloth that is soaked with water and wrung tightly, without undue pressure. Do not attempt to clean the 43521A internally.

Connection to the 4352B and External Signal Source

The 43521A is used by connecting it to the 4352B (VCO/PLL Signal Analyzer) and the external signal source. To operate the 43521A, the 4352B with the firmware of Rev 2.00 or greater is required. All parts required for the connection including cables and connectors will come with the 43521A and the 4352B. For the information on the accessories of the 4352B, refer to Chapter 3 of the 4352B Function Reference.

Connections on the Front Panel

Make connections as shown in Figure 2-1. For how to connect a DUT (Device Under Test), refer to Chapter 5 of the 4352B Function Reference.

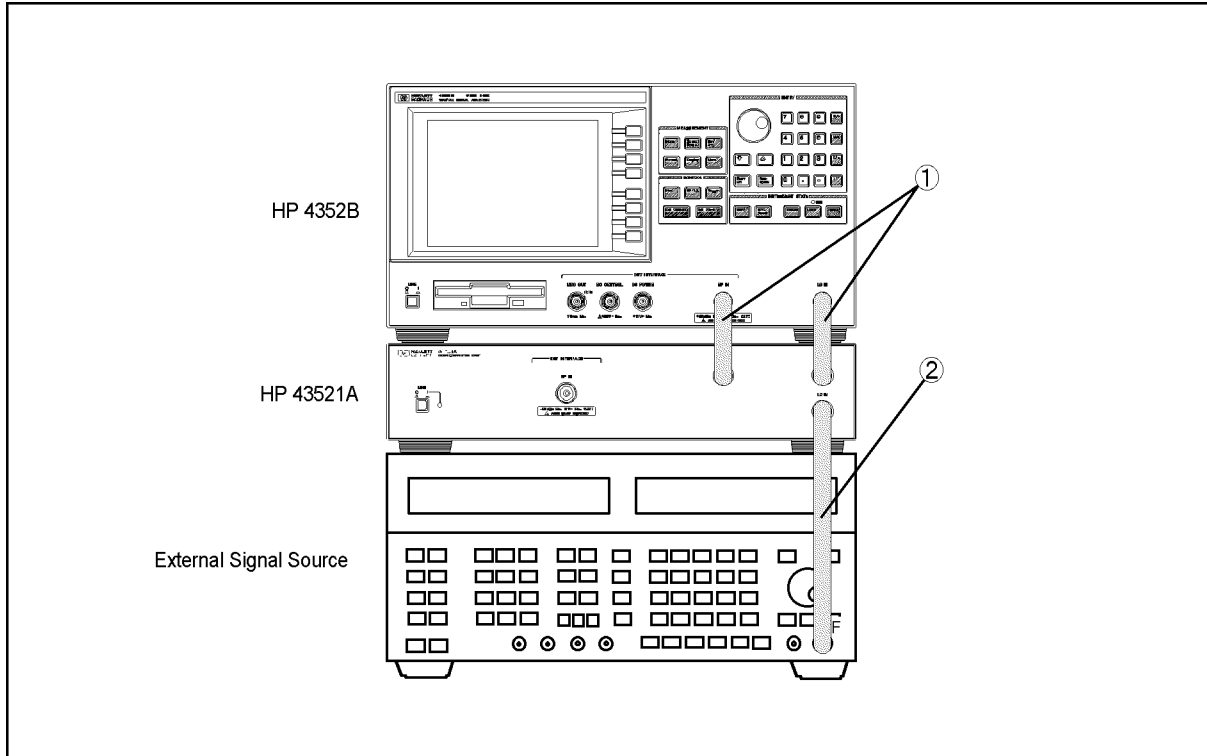

cd00501

Figure 2-1. Connections on the Front Panel

Table 2-1. Parts Used on the Front Panel

No.	Name	Agilent Part Number	Connection Locations
①	N-N cable (18 cm x 2)	8120-4387	The RF IN connector of the 4352B and the RF OUT connector of the 43521A, the LO IN connector of the 4352B and the LO OUT connector of the 43521A
②	N-N cable	41951-61602 (accessory of the 4352B)	The FR output connector of the external signal generator and the LO IN connector of the 43521A

Connections on the Rear Panel

Make connections as shown in Figure 2-2.

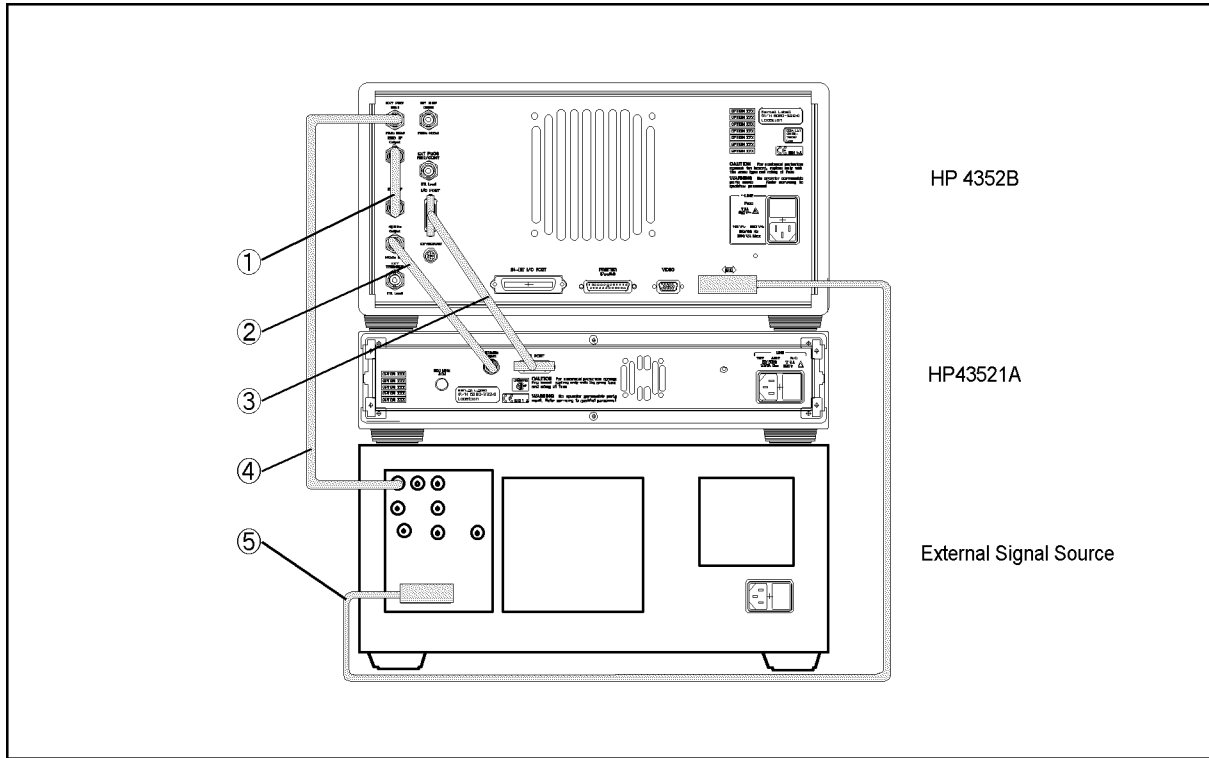

cd00502

Figure 2-2. Connections on the Rear Panel

Table 2-2. Parts Used on the Rear Panel

No.	Name	Agilent Part Number	Connection Locations
①	BNC-BNC connector	1250-1859 (accessory of the 4352B)	The 2ND IF Output connector and the 2ND IF Input connector of the 4352B
②	BNC-BNC cable (30 cm)	8120-1838	The 40MHz Output connector of the 4352B and the 40MHz Input connector of the 43521A
③	15-pin D-Sub cable	04380-61601	The I/O PORT connector of the 4352B and the I/O PORT connector of the 43521A
④	BNC-BNC cable (60 cm)	8120-1839 (accessory of the 4352B)	The EXT REF Input connector of the 4352B and the 10MHz OUT connector of the external signal generator
⑤	GPIB cable	10833A (accessory of the 4352B)	The GPIB connector of the 4352B and the GPIB connector of the external signal generator

Power Requirements

Ratings of the Power Source

The 43521A requires the following power source:

Voltage : 90 to 132 Vac or 198 to 264 Vac

Frequency : 47 to 63 Hz

Power : 100 VA maximum

Power Cable

In accordance with international safety standards, this instrument is equipped with a three-wire power cable. When connected to an appropriate ac power outlet, this cable grounds the instrument frame.



The type of power cable shipped with each instrument depends on the country of destination. Refer to Figure 2-3 for the part numbers of the power cables available.

Warning

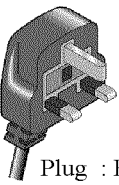
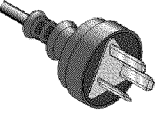
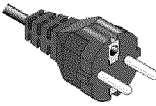
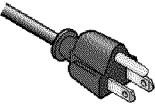

For protection from electrical shock, the power cable ground must not be defeated.

The power plug must be plugged into an outlet that provides a protective earth ground connection.

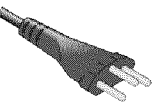
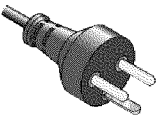
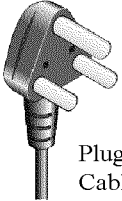
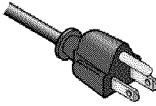
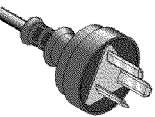
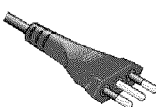
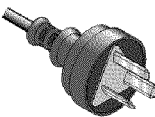
<p>OPTION 900</p>  <p>United Kingdom</p> <p>Plug : BS 1363/A, 250V, 10A Cable: HP 8120-1351</p>	<p>OPTION 901</p>  <p>Australia/ New Zealand</p> <p>Plug : AS 3112, 250V, 10A Cable: HP 8120-1369</p>
<p>OPTION 902</p>  <p>Continental Europe</p> <p>Plug : CEE 7 Standard Sheet VII, 250V, 10A Cable: HP 8120-1689</p>	<p>OPTION 903</p>  <p>U.S./ Canada</p> <p>Plug : NEMA 5-15P, 125V, 10A Cable: HP 8120-1378</p>
<p>OPTION 904</p>  <p>U.S./ Canada</p> <p>Plug : NEMA 6-15P, 250V, 6A Cable: HP 8120-0698</p>	<p>OPTION 906</p>  <p>Switzerland</p> <p>Plug : SEV Type 12, 250V, 10A Cable: HP 8120-2104</p>
<p>OPTION 912</p>  <p>Denmark</p> <p>Plug : SR 107-2-D, 250V, 10A Cable: HP 8120-2956</p>	<p>OPTION 917</p>  <p>India/ Republic of S.Africa</p> <p>Plug : IEC 83-B1, 250V, 10A Cable: HP 8120-4211</p>
<p>OPTION 918</p>  <p>Japan</p> <p>Plug : JIS C 8303, 125V, 12A Cable: HP 8120-4753</p>	<p>OPTION 920</p>  <p>Argentina</p> <p>Plug : Argentine Resolution 63, Annex IV, 250V, 10A Cable: HP 8120-6870</p>
<p>OPTION 921</p>  <p>Chile</p> <p>Plug : CEI 23-16, 250V, 10A Cable: HP 8120-6978</p>	<p>OPTION 922</p>  <p>China</p> <p>Plug : GB 1002, 250V, 10A Cable: HP 8120-8376</p>
<p>NOTE: Each option number includes a 'family' of cords and connectors of various materials and plug body configurations (straight, 90° etc.).</p>	

OPT9XXE

Figure 2-3. Optional Power Cables

Front Panel and Rear Panel

This chapter explains the front and rear panels of the 43521A (Downconverter Unit). How to use the entire 4352S including the 43521A is described in Chapter 5 of the 4352B Function Reference. Related sample programs are found in “Frequency Transient Measurement” in Chapter 12 of the 4352B GPIB Programming Manual.

Front Panel

Figure 3-1 shows the configuration of the front panel.

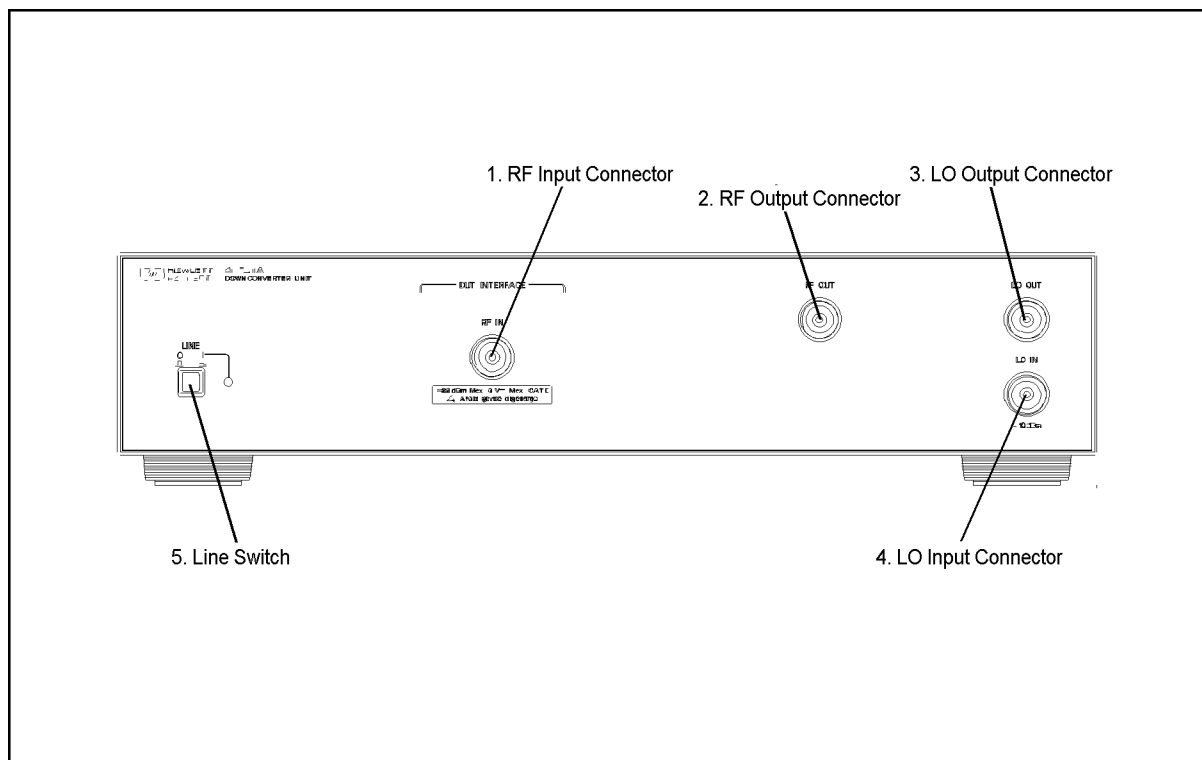

cd00505

Figure 3-1. Front Panel

1. RF Input Connector

Receives the RF output signal from the device under test (signal to be measured).

INSTALLATION CATEGORY I

2. RF Output Connector

The RF signal (signal to be measured) inputted to the RF input connector is outputted from this connector, and sent to the RF input connector of the 4352B (VCO/PLL Signal Analyzer) through the N-N cable. When the frequency band setting of this test system is 10 MHz to 3 GHz, the signal inputted to the RF input connector is outputted from this connector as it is. When the frequency band setting is not 10 MHz to 3 GHz, it is converted to an IF frequency signal and then outputted.

3. LO Output Connector

The signal from this connector is sent to the LO IN connector of the 4352B (VCO/PLL Signal Analyzer) through the N-N cable. The signal outputted from this connector is as follows: if the frequency band setting of this test system is 10 MHz to 3 GHz, the signal inputted to the LO input connector is outputted; if it is outside of 10 MHz to 3 GHz, the signal from the internal oscillator of the 43521A (600 MHz) is outputted.

4. LO Input Connector

Receives the output signal from the external signal generator.

5. Line Switch

Toggles on/off the power each time the button is pressed. | and ○ indicate ON and OFF, respectively. When the switch is ON, the right lamp is lit in green.

Rear Panel

Figure 3-2 shows the configuration of the rear panel.

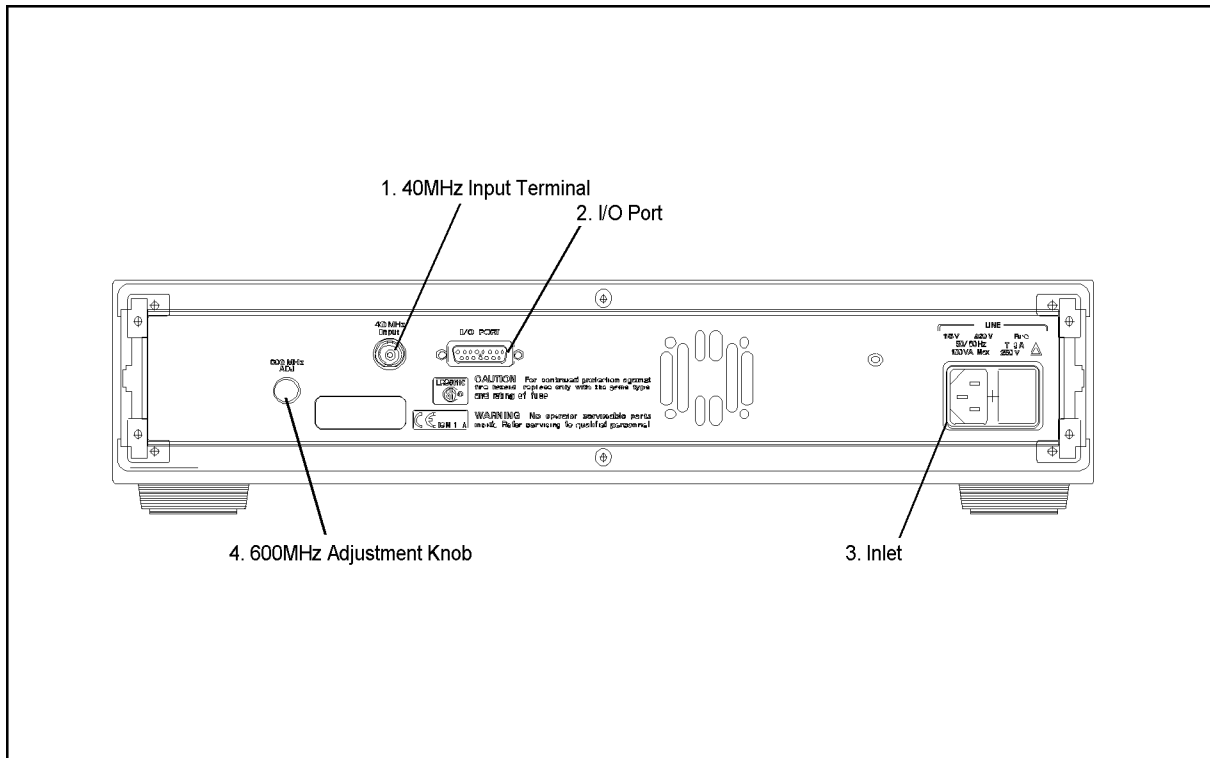

cd00506

Figure 3-2. rear panel

1. 40 MHz Input Terminal

To improve the frequency accuracy of the 600-MHz signal inside the 43521A, the 40-MHz signal from the rear panel of the 4352B (VCO/PLL Signal Analyzer) is inputted to this connector to provide phase locking for synchronizing the 600-MHz signal to the 40-MHz signal.

2. I/O Port

Receives the digital signal from the I/O port connector on the rear panel of the 4352B. All operations of the 43521A are controlled by this signal.

3. Inlet

Connects the power cable to this inlet. To replace the fuse, please see “Replacing the Fuse” in this chapter.

4. 600 MHz Adjustment Knob

Adjusts the frequency of the 600-MHz signal outputted from the LO output connector. For usual use, adjustment is not required. It is required only at periodical calibration of the 43521A. For details, refer to the 43521A Service Manual.

Replacing the Fuse

Select a proper fuse according to the Table 3-1.

Table 3-1. Rating of Fuse

Rating	Part Number
3A 250Vac UL/CSA type Time delay	2110-0381

For ordering the fuse, contact your nearest Agilent Technologies Sales and Service Office.

Replacing the Fuse

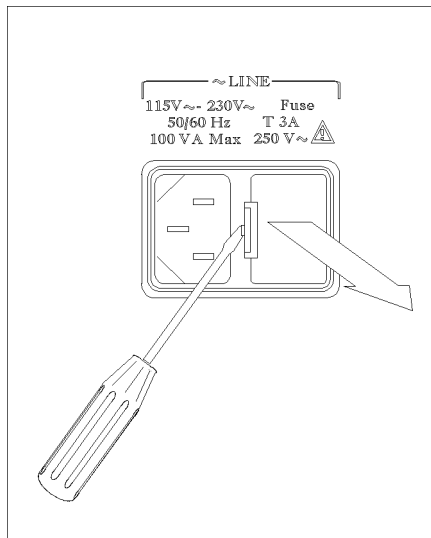

Lever a small minus screwdriver to dismount the fuse holder next to the AC line receptacle on the rear panel.

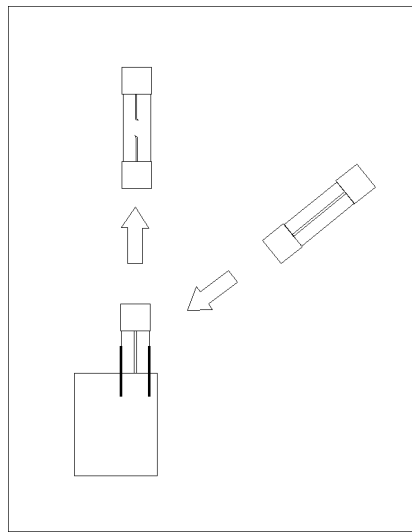

Replace the fuse in the fuse holder.

Caution



When replacing the fuse, be sure to check that the rating and the type are correct. Do not use a repaired fuse or short-circuited fuse holder.

Rack/Handle Installation

Rack/Handle Installation

This instrument can be rack-mounted and used as a component in a measurement system. Figure 4-1 shows how to rack-mount the instrument.

Table 4-1. Rack Mount Kits

Option	Description	Agilent Part Number
1CN	Front Handle Kit	5063-9226
1CM	Rack Mount Kit	5063-9212
1CP	Rack Mount & Handle Kit	5063-9219

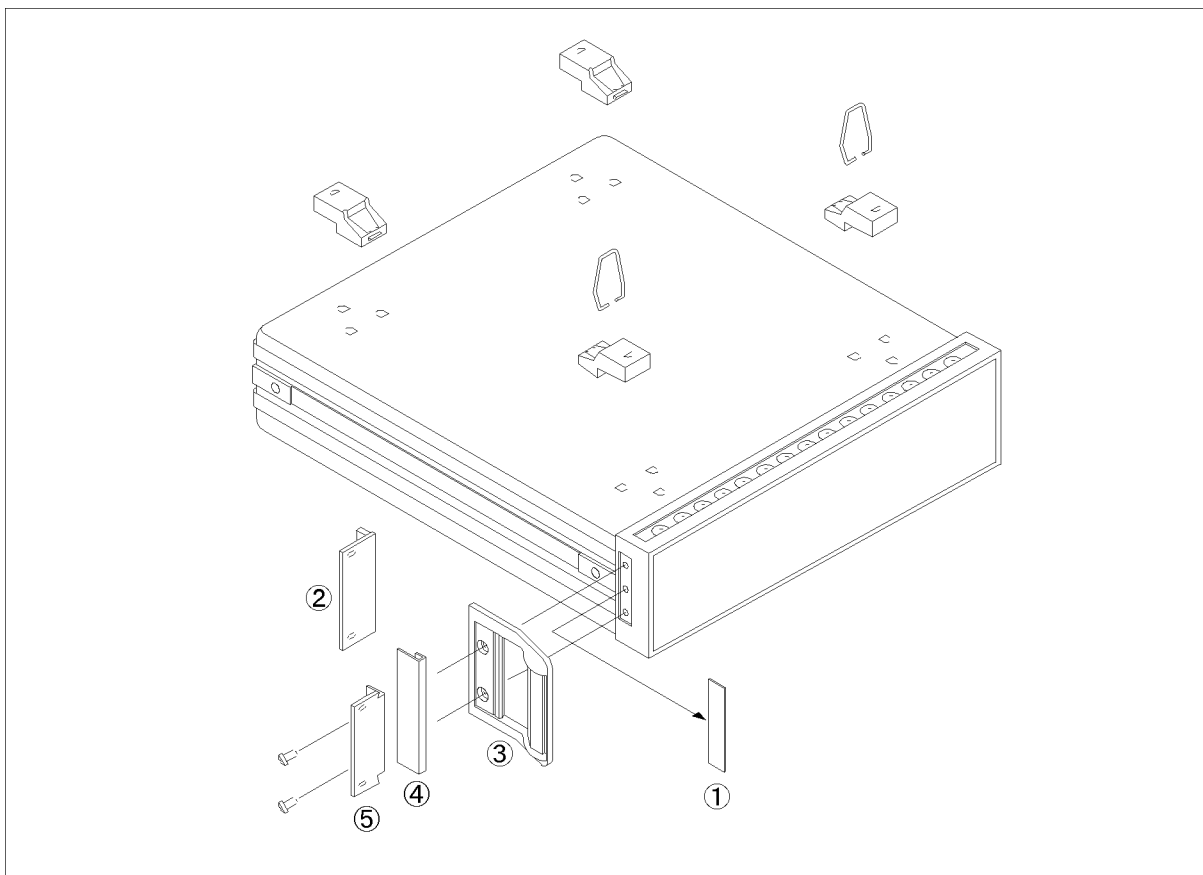

Figure 4-1. Rack Mount Kit Installation

Option 1CN Handle Kit

Option 1CN includes a pair of handles and accessories to attach them to the instrument.

Installing the Handle

1. Remove the cosmetic panels ① affixed to both sides of the frame on the front panel. (See Figure 4-1.)
2. Attach the handles ③ to both sides of the instrument using the screws provided.
3. Attach the trim strips ④ to the handles.

Option 1CM Rack Mount Kit

Option 1CM includes a pair of flanges and accessories to mount the instrument to an EIA-compliant standard rack (482.6 mm wide).

Mounting into the Rack

1. Remove the cosmetic panels ① affixed to both sides of the frame on the front panel. (See Figure 4-1.)
2. Attach the flanges ② to both sides of the instrument using the screws provided.
3. Remove all the four feet. (Lift the tab and slide the foot in the arrow direction.)
4. Mount the instrument into the rack.

Option 1CP Rack Mount & Handle Kit

Option 1CP includes a pair of flanges, handles, and accessories.

Mounting into the Rack (with Handles)

1. Remove the cosmetic panels ① affixed to both sides of the frame on the front panel. (See Figure 4-1.)
2. Attach the handles ③ and the flanges ⑤ to both sides of the instrument using the screws provided.
3. Remove all the four feet. (Lift the tab and slide the foot in the arrow direction.)
4. Mount the instrument into the rack.

Specifications

The specifications mean the performance standards and operation limits. They are the 43521A's performance guaranteed, unless otherwise specified, over the temperature range of 0°C to 40°C and after a warm-up time of at least 30 minutes has elapsed from power-on. Information provided as *typical*, *reference*, or *approximate*, though not specifications, is intended to serve as reference data for efficient operation of the 43521A.

Specifications of the 43521A

RF Power Measurement

Frequency band	2.4 GHz to 12.6 GHz
VSWR	<1.5
Input level	
When the input attenuator is 0 dB:	-20 dBm to 0 dBm
When the input attenuator is >0 dB:	-20 dBm to +20 dBm
Resolution	0.01 dB
Measurement accuracy	Table 5-1

Table 5-1. RF Power Measurement Accuracy

Level of Input Signal	Temperature Range	
	23±10°C	0 to 40°C
-20 dBm to 0 dBm (ATT=0dB)	2.4 GHz to 4 GHz ±1.5dB 4 GHz to 8 GHz ±2.0 dB 8 GHz to 12.6 GHz ±2.5 dB	2.4 GHz to 8 GHz ±2.0 dB 8 GHz to 12.6 GHz ±2.5 dB
≤15 dBm (ATT>0 dB)	2.4 GHz to 4 GHz ±1.5 dB 4 GHz to 8 GHz ±2.0 dB 8 GHz to 12.6 GHz ±2.5 dB	(Same as left)
≤20 dBm (ATT>0 dB)	2.4 GHz to 4 GHz ±1.5 dB (Reference) 4 GHz to 8 GHz ±2.0 dB (Reference) 8 GHz to 12.6 GHz ±2.5 dB (Reference)	(Same as left)

* Peak voltage response

* The above specifications are applicable when the 43521A is controlled by the 4352B and the measurement result is displayed on the 4352B.

@6 GHz,-5 dBm,23±10°C	±0.8 dB(Typical)
@12 GHz,-5 dBm,23±10°C	±1.0 dB(Typical)

Operating Environment

Temperature	0°C to 40°C
Humidity	15% to 95% RH
Altitude	0 to 2000 m
Warm up time	30 minutes

Non-Operating Environment

Temperature	-20°C to 60°C
Humidity	15% to 95% RH @wet bulb temperature $\leq 45^\circ\text{C}$, without condensation
Altitude	0 to 4572 m

Others

EMC	Complies with those standards
Emission: EN 55011:1991 / CISPR 11:1990 Group 1, Class A	EN/IEC 61000-3-2 1995 EN/IEC 61000-3-3 1995
Immunity: EN 50082-1:1992	EN/IEC 61000-4-2:1995 4 kV CD / 8 kV AD EN/IEC 61000-4-3:1995 3 V/m, 27-1000 MHz, 80 % AM EN/IEC 61000-4-4:1995 Main 1 kV / Signal 0.5kV EN/IEC 61000-4-5:1995 Common 2 kV / Normal 1 kV EN/IEC 61000-4-6:1996 3 V, 0.15-80 MHz, Main

This ISM device complies with Canadian ICES-001.
Cet appareil ISM est conforme à la norme NMB-001 du Canada.

SafetyComplies with EN61010-1(1993) + A2(1995)/IEC 61010-1(1990) + A1(1992) + A2(1995)

Complies with CSA C22.2 No.1010.1-92

Power requirements 90 V to 132 V, or 198 V to 264 V, 47 to 63 Hz, 100 VA max
Weight 8 kg max
Dimensions 425(W) × 101(H) × 553(D) mm

RF input terminal (Reference)

Heterodyne path gain 20 dB @ 6 GHz
Insertion Loss in Direct Path: 0.5dB @ 3 GHz

LO input terminal (Reference)

Input level +10 dBm
Frequency range 10 MHz to 6 GHz
Insertion Loss in Direct Path: 0.5dB @ 3 GHz

LO output terminal (Reference)

600 MHz Output Level $\geq +8$ dBm
600 MHz Frequency Accuracy 600 MHz \pm 50 ppm

System Specifications

The following provide the specifications of the system in which the 43521A is connected to the 4352B (VCO/PLL Signal Analyzer) and the external signal source. It is assumed that the 43521A is locked by the 40 MHz signal from the 4352B. All values, except for the RF power measurement in 2-1. Tester Mode, are reference values. Note that same specifications as those of the 4352B are not shown.

1. When Frequency Band is 10 MHz to 3 GHz

RF Power Measurement (common to the tester mode and the analyzer mode)

Measurement accuracy

When the frequency ≤ 2 GHz..... Add ± 0.1 dB to the accuracy of the 4352B.

When the frequency is 2 GHz to 3 GHz..... Add ± 0.2 dB to the accuracy of the 4352B.

The same specifications as the 4352B are applicable for other measurement parameters.

2. When Frequency Band is other than 10 MHz to 3 GHz

2-1. Tester Mode

RF Power Measurement

Same as the specifications of the 43521A.

Frequency Measurement

Frequency band 2.4 GHz to 12.6 GHz

Resolution Same as the 4352B.

Measurement accuracy Same as the 4352B.

FM Deviation Measurement

Measurement range Same as the 4352B.

Deviation resolution Same as the 4352B.

Deviation measurement accuracy Same as the 4352B.

Residual FM Same as the 4352B.

C/N Ratio Measurement

Offset frequency range Same as the 4352B.

Phase noise Table 5-2

The table is applicable when the 8665B (with Option 004) is used as the external signal source. If the external signal source is the 8664A (with Option 004), use values of up to 6 GHz; if it is the 8665A (with Option 004), use values of up to 9 GHz.

Table 5-2. Noise Floor of Phase Noise

Offset Freq (Hz)		100	300	600	1k	3k	6k	10k	30k	60k	100k	300k	600k	1M	3M	6M	9M
RF Freq	3 GHz	-68	-75	-85	-93	-111	-120	-125	-132	-135	-137	-145	-149	-150	-151	-151	-151
	6 GHz	-63	-68	-79	-88	-106	-115	-119	-126	-129	-131	-139	-144	-147	-149	-150	-150
	9 GHz	-57	-65	-76	-84	-101	-109	-114	-120	-123	-125	-133	-139	-143	-145	-145	-146
	12 GHz	-58	-63	-73	-81	-99	-108	-113	-120	-123	-125	-134	-138	-142	-145	-147	-147

Measurement accuracy Same as the 4352B.

2-2. Analyzer Mode

RF Power Characteristics vs. DC Control Voltage Measurement

Same as the RF Power Measurement in the 43521A.

Frequency/Tuning Sensitivity Characteristics vs. DC Control Voltage Measurement

Same as the frequency measurement in the tester mode.

Phase Noise Characteristics vs. Offset Frequency Measurement

Same as the C/N ratio measurement in the tester mode.

Frequency Transient Measurement

Frequency accuracy Same as the 4352B.

Frequency span 2 MHz, 20 MHz, 512 MHz (MAX)

Measurement resolution 50 Hz, 500 Hz, 12.8 kHz (MAX)

Spectrum Measurement

When the detection mode is specified to positive peak

Absolute level accuracy

For @-10 dBm input, attenuator = 10 dB, ±3dBm

Relative level accuracy Same as the 4352B.

Manual Changes

Introduction

This appendix contains the information required to adapt this manual to earlier versions or configurations of the 43521A than the current printing date of this manual. The information in this manual applies directly to the 43521A serial number prefix listed on the title page of this manual.

Manual Changes

To adapt this manual to your 43521A see Table A-1 and make all the manual changes listed opposite your instrument's serial number and firmware version.

Instruments manufactured after the printing of this manual may be different from those documented in this manual. Later instrument versions will be documented in a manual changes supplement that will accompany the manual shipped with that instrument.

If your instrument's serial number is not listed on the title page of this manual or in Table A-1, it may be documented in a *yellow MANUAL CHANGES* supplement.

In additions to change information, the supplement may contain information for correcting errors (Errata) in the manual. To keep this manual as current and accurate as possible, Agilent Technologies recommends that you periodically request the latest *MANUAL CHANGES* supplement.

For information concerning serial number prefixes not listed on the title page or in the *MANUAL CHANGE* supplement, contact the nearest Agilent Technologies office.

Table A-1. Manual Changes by Serial Number

Serial Prefix or Number	Make Manual Changes
Not Applicable	

Serial Number

Agilent Technologies uses a two-part, ten-character serial number that is stamped on the serial number plate (Refer to Figure A-1) attached to the rear panel. The first five characters are the serial prefix and the last five digits are the suffix.



Figure A-1. Serial Number Plate

REGIONAL SALES AND SUPPORT OFFICES

For more information about Agilent Technologies test and measurement products, applications, services, and for a current sales office listing, visit our web site: <http://www.agilent.com/find/tmdir>. You can also contact one of the following centers and ask for a test and measurement sales representative.

11/29/99

United States:

Agilent Technologies
Test and Measurement Call Center
P.O.Box 4026
Englewood, CO 80155-4026
(tel) 1 800 452 4844

(fax) (61 3) 9272 0749
(tel) 0 800 738 378 (New Zealand)
(fax) (64 4) 802 6881

Canada:

Agilent Technologies Canada Inc.
5150 Spectrum Way
Mississauga, Ontario
L4W 5G1
(tel) 1 877 894 4414

Asia Pacific:

Agilent Technologies
24/F, Cityplaza One, 1111 King's Road,
Taikoo Shing, Hong Kong
(tel) (852)-3197-7777
(fax) (852)-2506-9284

Europe:

Agilent Technologies
Test & Measurement
European Marketing Organization
P.O.Box 999
1180 AZ Amstelveen
The Netherlands
(tel) (31 20) 547 9999

Japan:

Agilent Technologies Japan Ltd.
Call Center
9-1, Takakura-Cho, Hachioji-Shi,
Tokyo 192-8510, Japan
(tel) (81) 426 56 7832
(fax) (81) 426 56 7840

Latin America:

Agilent Technologies
Latin American Region Headquarters
5200 Blue Lagoon Drive, Suite #950
Miami, Florida 33126
U.S.A.
(tel) (305) 267 4245
(fax) (305) 267 4286

Australia/New Zealand:

Agilent Technologies Australia Pty Ltd
347 Burwood Highway
Forest Hill, Victoria 3131
(tel) 1-800 629 485 (Australia)